



HIGH SECURITY ACCESS DOOR Model DSB-123SD For All Types of Construction

DATE



SPECIFICATIONS

GENERAL SCOPE:

Access doors shall be Karp Type DSB-123SD as manufactured by Karp Associates, Inc., Melville, N.Y. Sizes shall be as indicated on the drawings.

CONSTRUCTION:

1. Frame shall be 3/16" x 2" x 2" angle welded with joints ground smooth.
2. Door shall be 10 gage steel.
3. Hinges shall be heavy duty and welded to door and frame.
4. Locks shall be heavy duty detention type lock (or as specified). Additional locking devices shall be spanner-head cam latches welded flush to the surface of the door.
5. 1/4" mounting holes are included on all frames, masonry anchor straps are optional.
6. Finish shall be prime coat of rust inhibitive electrostatic powder, baked white enamel.

STANDARD SIZES

DOOR SIZE H X W (IN.)	WALL/CEILING OPENING (IN.)	SHIP WT. (LBS.)
12 x 12	12 1/2 x 12 1/2	35.0
16 x 16	16 1/2 x 16 1/2	44.0
18 x 18	18 1/2 x 18 1/2	49.0
24 x 24	24 1/2 x 24 1/2	65.0
36 x 24	36 1/2 x 24 1/2	80.0
36 x 36	36 1/2 x 36 1/2	115.0

PROJECT DATA					
Project Name:					
Architect:					
Contractor:					
Agent/Customer Name:					
Tagging Instructions:					
Special Instructions:					
PROJECT SCHEDULE					
Qty.	H	W	No. of Latches	Finish	Remarks

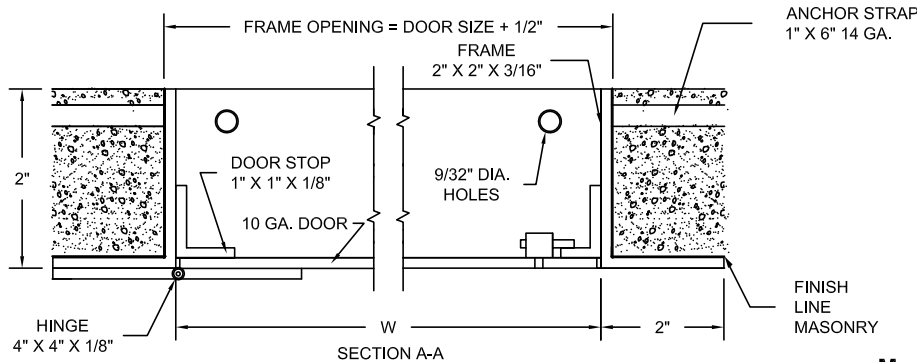
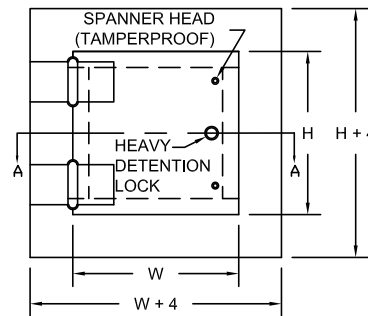

Made with Union Labor



FOR MORE INFORMATION CALL 1-888-926-1365
 Superior Specialty Supply • 9 Council Drive • PO Box 417 • Woodsboro, MD 21798 • www.sssupply.com