



VALVE BOXES Model KSMB (Surface Mounted)

DATE

C:\Users\cyu\Desktop\thumb_kamb.jpg

SPECIFICATIONS

GENERAL SCOPE:

Access doors shall be Karp Type KSMB as manufactured by Karp Associates, Inc., Melville, N.Y. Sizes shall be as indicated on the drawings.

CONSTRUCTION:

1. Box shall be 16 gage steel and door shall be 14 gage steel.
2. Hinge shall be exposed, continuous piano hinge.
4. Locks shall be flush and screwdriver operated with cam and studs, or shall be key operated cylinder lock with automatic dust shutter.
5. Holes 1/4" diameter shall be provided for anchoring to wall.
6. Finish shall be prime coat of rust inhibitive electrostatic powder, baked white enamel.

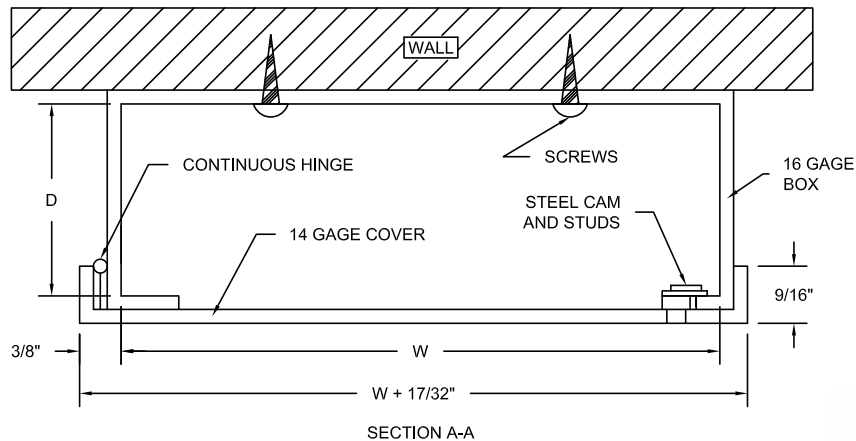
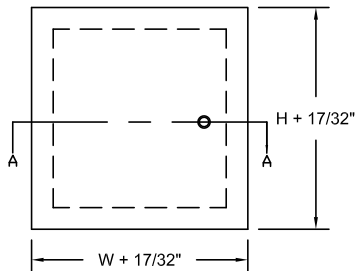

Made with Union Labor

PROJECT DATA						
Project Name:						
Architect:						
Contractor:						
Agent/Customer Name:						
Tagging Instructions:						
Special Instructions:						
PROJECT SCHEDULE						
Qty.	H	W	D	No. of Latches	Finish	Remarks



FOR MORE INFORMATION CALL 1-888-926-1365
 Superior Specialty Supply • 9 Council Drive • PO Box 417 • Woodsboro, MD 21798 • www.sssupply.com