



FLUSH DRYWALL ACCESS DOOR

Model KDW

For Wall and Ceilings



KARP ASSOCIATES, INC.

DATE

SPECIFICATIONS

GENERAL SCOPE:

Access doors shall be Karp Type KDW as manufactured by Karp Associates, Inc., Melville, N.Y. Sizes shall be as indicated on the drawings.

CONSTRUCTION:

1. Frame shall be 16 gage steel and door shall 14 gage steel.
2. Trim shall be galvanized steel drywall bead.
3. Hinge shall be pin type hinge, spring loaded making door removable.
4. Latches shall be flush and screwdriver operated, or shall be key operated cylinder lock with automatic dust shutter.
5. Finish shall be prime coat of rust inhibitive electrostatic powder, baked white enamel.

* When hinge side is greater than 48", door shall have a continuous piano hinge for rigidity.

STANDARD SIZES

DOOR SIZE H X W (IN.)	WALL/CEILING OPENING (IN.)	NUMBER OF STUD LATCHES	SHIP WT. (LBS.)
6 x 6	6 3/8 x 6 3/8	1	1.8
8 x 8	8 3/8 x 8 3/8	1	2.4
10 x 10	10 3/8 x 10 3/8	1	3.3
12 x 12	12 3/8 x 12 3/8	1	5.8
14 x 14	14 3/8 x 14 3/8	2	6.5
16 x 16	16 3/8 x 16 3/8	2	8.8
18 x 18	18 3/8 x 18 3/8	2	11.1
22 x 22	22 3/8 x 22 3/8	4	15.3
24 x 24	24 3/8 x 24 3/8	5	17.2
36 x 24	36 3/8 x 24 3/8	5	25.9

PROJECT DATA					
Project Name:					
Architect:					
Contractor:					
Agent/Customer Name:					
Tagging Instructions:					
Special Instructions:					

PROJECT SCHEDULE					
Qty.	H	W	No. of Latches	Finish	Remarks

* The wall opening size for doors larger than 48 x 36 shall be 1/2" larger than the door size.

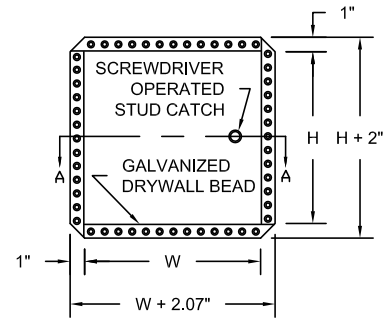
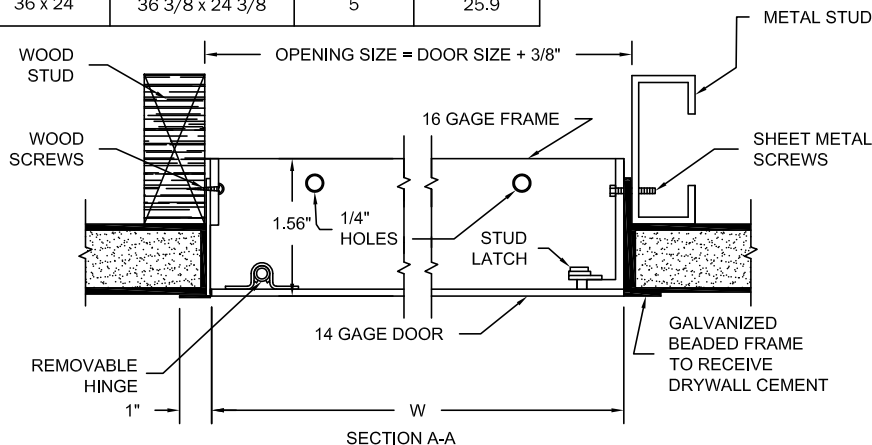

Made with Union Labor



FOR MORE INFORMATION CALL 1-888-926-1365
 Superior Specialty Supply • 9 Council Drive • PO Box 417 • Woodsboro, MD 21798 • www.sssupply.com