

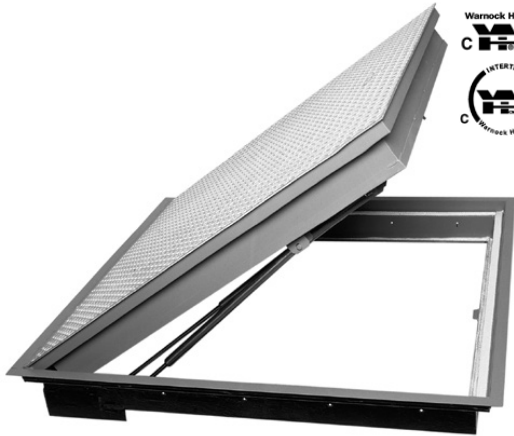

Three Generations of Quality Metal Products

MODEL FHD4R - Four Hour Insulated Fire-Rated Floor Door
Cast-In-Place Application



Tested and listed to standards: NFPA 288, ASTM E119, CAN/ULC S101 and NFPA 251; which states "Transmission of heat through the specimen (floor door) during the classification period (listed rating period) shall not have been as to raise the average temperature on its unexposed surface more than 139°C (250°F) above its initial temperature." Hose stream test standards: NFPA 252, UL 10(b), CAN4-S104 (ULC-S104) and UBC 7-2-94.

- Designed for simple installation, the contractor is not required to pour cement into the door panel or to apply intumescent coating on underside of the surrounding structure.
- Anchor straps are supplied for cast-in-place applications.
- Non-standard sizes available upon request.
- Optional: Self-closing mechanism available, contact MAXAM for more details.
- Please reference size chart page when ordering.
- Door panel standard with handle(s) on the underside.

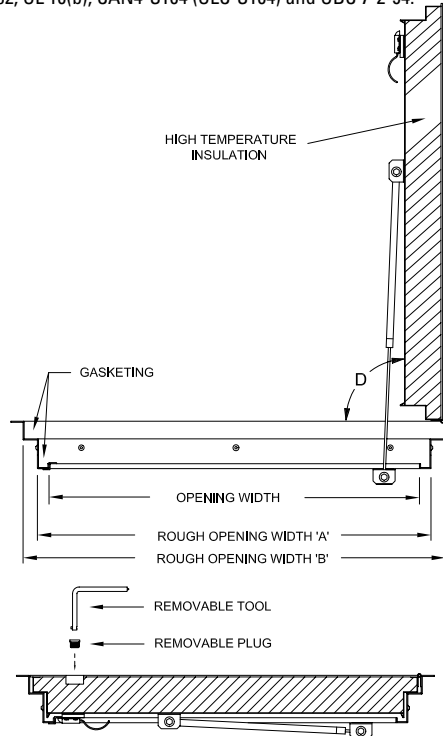

Door Panel

6.35mm (1/4") aluminum checker plate

Live Load

700 kg/sq. metre (150 lbs/sq. ft.)

Frames

2.75mm (12ga) and 1.99mm (14ga) satin finished (bonderized) steel

Hinge

Heavy-duty continuous zinc plated steel hinge with a brass pin

Gasket

Frame gasketed on all four sides of the upper and lower sections on the frame assembly.

Latch

316 stainless steel slam latch with a removable cover plug, operable from the top side by a removable tool and the underside by a spoon handle.

Optional Latch Operator

Hand operated recessed turn handle

Panel Operator

316 stainless steel nitrogen cylinders

Insulation

Door panel is filled with a high temperature insulation material.

Finishes

Steel, electrostatically applied grey primer
Aluminum, mill finish

Optional Finish

Door panel painted yellow with the following instructions painted in black:
"FIRE DOOR DO NOT STORE MATERIALS/
EQUIPMENT ON SURFACE".

Installation

Concrete: Supplied with stainless steel anchor straps for casting in place. Two part epoxy bituminous coating on outside of frame for cast-in-place applications.

Ordering

Please reference size charts.
Contact us at Maxam for more details.

Note: Fire-rated floor doors are non-returnable.

Guarantee

Manufacturer shall guarantee floor door against defects in material or workmanship for five years from date of shipping.

DOOR IS NOT TO BE EXPOSED TO RAIN, FOR DRY LOCATION USE ONLY.

Patented

DATE Sep. / 2018	REV. 1
---------------------	-----------



FOR MORE INFORMATION CALL 1-888-926-1365
Superior Specialty Supply • 9 Council Drive • PO Box 417 • Woodsboro, MD 21798 • www.sssupply.com